

The shortest universal
stacker of its class in
the world (EMD 115i)

Optimum driving
characteristics with fixed
ProTracLink torsion bar

On-board charger for
easy charging

Precise load positioning with
sensitive lifting of the load

Very low noise levels with
SilentDrive (optional)



EMD 115i/118

Electric pedestrian stacker (1,500/1,800 kg)

The EMD 115i/118 electric pedestrian controlled truck offers a wide range of options for almost all applications. Its short front-end length combined with an integrated support arm lift provides space for utmost flexibility in use.

The EMD 118 facilitates problem-free lifting of picked goods weighing up to 800 kg to a comfortable reach height as well as light stacking operations up to 1520 mm. Simultaneously, with its very short front-end length of just 628 mm, the EMD 118 is not just versatile and compact, but also ideal for use in shops, in very tight storage areas or on an HGV.

The EMD 115i impresses with its advanced lithium-ion technology in the form of a 17 KG battery case. In addition to rapid and boost charging, the truck's principal advantage is its noticeably smaller battery compartment, which in combination with the front end (l2) helps to reduce the overall weight of the forklift truck considerably. The forklift truck can be used in the narrowest of spaces and in weight-sensitive areas and is ideally suited

to conventional applications and use on HGVs. With a front-end length of just 558;mm, the EMD;115i is the shortest universal stacker of its class in the world.

A second vehicle truck model with shorter mast (ergonomic lift) provides the ideal conditions for comfortable order picking up to a height of 690;mm (with support arm lift: 812;mm) and goods transport with low intensity. If noise is a problem, the EMD offers a SilentDrive option to allow use to continue in noise-sensitive areas or at times when noise needs to be kept to a minimum.

EMD type pedestrian controlled trucks are flexible universal trucks for load transport over short distances and light-duty stacking tasks. In addition to short front-end lengths and a compact design, the trucks' is characterised by ease of handling and wide range of ergonomic benefits.

EMD 115i/118

EMD 115i
Ergo lift model

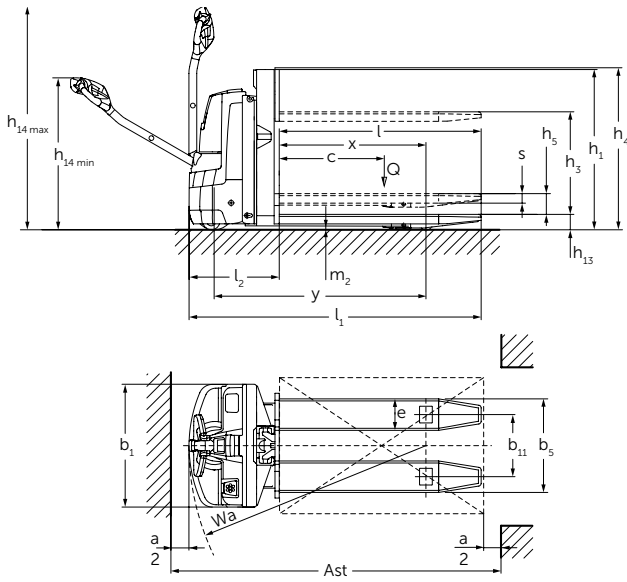

EMD 118
and EMD 115i

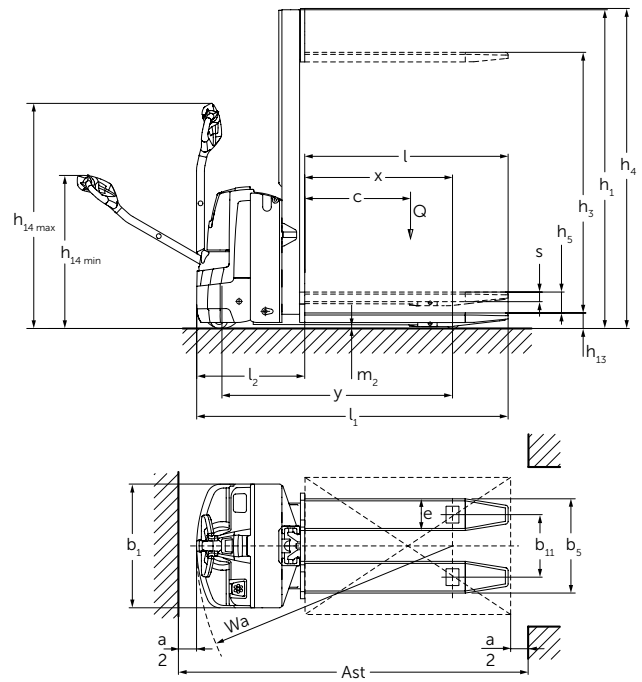

Technical data in line with VDI 2198

			Jungheinrich			
			EMD 115i	EMD 115i Ergo lift	EMD 118	
Identification	1.1	Manufacturer (abbreviation)				
	1.2	Model				
	1.3	Drive	Electric			
	1.4	Manual, pedestrian, stand-on, seated, order picker operation	pedestrian			
	1.5	Load capacity/rated load	Q t	1.5 ³⁾	1.5 ³⁾	1.8 ⁴⁾
	1.5.1	Load capacity/mast lift	Q t	0.8		
	1.5.2	Load capacity/support arm lift	Q t	1.5 ³⁾	1.5 ³⁾	2 ⁴⁾
	1.6	Load centre distance	c mm	600		
	1.8	Load distance	x mm	942		
1.9	Wheelbase	y mm	1,356	1,356	1,426	
Weights	2.1.1	Net weight incl. battery (see row 6.5)	kg	510	480	650
	2.2	Axle load with load front/rear	kg	660 / 1,350	635 / 1,345	720 / 1,730
	2.3	Axle load without load front/rear	kg	360 / 150	335 / 145	470 / 180
Wheels / frame	3.1	Tyres	PU			
	3.2	Tyre size, front	mm	Ø 230 x 65		
	3.3	Tyre size, rear	mm	Ø 75 x 95 / Ø 75 x 75		
	3.4	Additional wheels (dimensions)	mm	Ø 100 x 40		
	3.5	Wheels, number front/rear (x = driven wheels)		1x +2 / 2 or 4		
	3.6	Tread width, front	b ₁₀ mm	508		
	3.7	Tread width, rear	b ₁₁ mm	365		
Basic dimensions	4.2	Mast height (lowered)	h ₁ mm	1,865	955	1,865
	4.3	Free lift	h ₂ mm	1,520	600	1,520
	4.4	Lift	h ₃ mm	1,520	600	1,520
	4.5	Extended mast height	h ₄ mm	1,987	1,077	1,987
	4.6	Initial lift	h ₅ mm	122		
	4.9	Height of tiller in drive position min. / max.	h ₁₄ mm	797 / 1,313		
	4.15	Height, lowered	h ₁₃ mm	86		
	4.19	Overall length	l ₁ mm	1,748	1,748	1,818
	4.20	Length to face of forks	l ₂ mm	558	558	628
	4.21	Overall width	b ₁ /b ₂ mm	726		
	4.22	Fork dimensions	s/e/l mm	56 / 185 / 1,190		
	4.25	Width across forks	b ₅ mm	550		
	4.32	Ground clearance, centre of wheelbase	m ₂ mm	20		
	4.33	Aisle width for pallets 1000 x 1200 sideways	Ast mm	1,948 ²⁾	1,948 ²⁾	2,018 ²⁾
4.34	Aisle width for pallets 800 x 1200 lengthways	Ast mm	1,958 ¹⁾	1,958 ¹⁾	2,028 ¹⁾	
4.35	Turning radius	W _a mm	1,452 ⁵⁾	1,452 ⁵⁾	1,522 ⁵⁾	
Performance data	5.1	Travel speed, laden/unladen	km/h	6 / 6		
	5.2	Lift speed, laden/unladen	m/s	0.18 / 0.3		
	5.3	Lowering speed, laden/unladen	m/s	0.19 / 0.19		
	5.7	Gradeability laden/unladen	%	8 / 15		
	5.10	Service brake		regenerative		
Electrics	6.1	Drive motor, output S2 60 min.	kW	1.0		
	6.2	Lift motor, output at S3 15%	kW	1.2		
	6.3	Battery as per DIN 43531 /35/36 A, B, C, no		43535 B		
	6.4	Battery voltage/nominal capacity K5	V/Ah	24 / 40	24 / 40	24 / 150
	6.5	Battery weight	kg	17	17	151
	6.6	Energy consumption according to VDI cycle	kWh/h	0.36		
Misc.	8.1	Type of drive control		AC SpeedControl		
	8.4	Sound pressure level at operator's ear as per EN 12053	dB (A)	64		

¹⁾ diagonal according to VDI: + 198 mm

²⁾ diagonal according to VDI: + 313 mm

³⁾ In double-deck operation: Mast lift 0.75 t / overall load max. 1.5 t

⁴⁾ In double-deck operation: Mast lift 0.8 t / overall load max. 1.8 t

⁵⁾ Load section raised, when load section lowered + 48 mm

Benefit from the advantages



Double-deck operation – loading of two pallets one over the other



Optimum view of the forks and surrounding areas



Short EMD 115i mast for ergonomic order picking up to a height of 690 mm



Easy charging at any 230 V mains socket thanks to on-board charger.

Flexible use

The integrated support arm lift and permanently connected ProTracLink caster wheels make the EMD a flexible truck for universal use:

- Ideal in pallet truck applications over short transport distances with loads up to 2000 kg.
- As a double-deck truck for efficiently transporting two Euro pallets stacked on top of each other (support arm lift 1000 kg/mast lift 800 kg).
- Can be used as a stacker truck for light stacking tasks up to a height of 1520 mm.

Working safety in very confined spaces

Not least due to its compact dimensions, the EMD is ideally suited to almost any application, even in confined spaces:

- Unobtrusive and reliable handling in shops with public traffic thanks to very short front-end length and narrow aisle width.
- Innovative mast design with integrated viewing window and special shape of the battery lid for optimum view of the load.
- Low service weight for use in a delivery truck, on intermediate floors or in a lift.

Optimum pallet handling

Numerous performance features make stacking and retrieving with the EMD particularly safe and efficient, including:

- Precise and gentle lifting of the load by speed-controlled hydraulic motor.
- Gentle depositing of loads using proportional hydraulics (optional).
- Long safety tiller ensures sufficient distance between the operator and the forklift truck.
- Optimum view of the fork tips, even for small operators.

Stable handling

The sprung, hydraulically cushioned support wheels of the EMD are connected via the patented "ProTracLink" suspension which distributes the force depending on the situation: This suggests applications on a loading ramp and loading/unloading HGVs.

Always informed

The 2-inch display (optional) as the main display and setting instrument offers the user control at a glance:

- Battery discharge indication, operation hours and fault diagnostics.
- Choice of three travel programmes.
- Activation of the truck by EasyAccess via softkey, PIN code or transponder card (optional).

Innovative lithium-ion technology

The EMD offers a choice of a 40 Ah lithium-ion battery box (EMD 115i) or a 110 Ah lithium-ion battery (optional on EMD 118):

- Usage times of up to three hours with 40 Ah battery box (EMD 115i).
- Boost charging: After a boost charging time of just 30 minutes, the battery is charged to 50% and after 80 minutes to 100%.
- No battery changing necessary.
- Proof voltage always ensures full power.
- Costs are saved due to longer service life and low maintenance compared with lead-acid batteries.
- No charging rooms and ventilation required as there is no build up of gas.
- Easy charging at any 230 V mains socket thanks to on-board charger.

Additional equipment

Comprehensive accessories allow for individual tailoring to your requirements:

- Tandem load rollers.
- Load guard.
- Cold store version.
- SilentDrive for quiet operation.

Jungheinrich UK Ltd.

Head Office:
Sherbourne House
Sherbourne Drive
Tilbrook
Milton Keynes MK7 8HX
Telephone 01908 363100
Fax 01908 363180

info@jungheinrich.co.uk
www.jungheinrich.co.uk

The German production facilities in Norderstedt, Moosburg and Landsberg are certified. **ISO 9001**
ISO 14001

Jungheinrich fork lift trucks meet European safety requirements.



JUNGHEINRICH
Machines. Ideas. Solutions.