

High performance trucks with low energy consumption

Tailored performance based on application with efficiency and Drive&Lift Plus models

Parameter steering (optional)

Sideways battery removal with SnapFit

Ergonomic and easily adjustable operators environment

Driver assistance systems to suit any application



EFG 425k/425/430k/430/S30

Electric four-wheel counterbalance trucks (2,500/3,000 kg)

Our Pure Energy technology concept enables us to achieve the best possible energy efficiency coupled with maximum performance.

By using the most advanced 3-phase AC technology in combination with our own manufactured electronic controller as well as an efficient and compact hydraulic unit, we have been able to significantly reduce energy consumption – while simultaneously increasing throughput. This is verified by tests as per the VDI cycle: At full throughput, our new Series 4 EFG consumes up to 10% less energy than a comparable competitor model.

A choice of configuration packages with variable travel/lift speeds from the Efficiency and Drive&Lift Plus modules will complete your transport and stacking operations with maxi-

mum energy efficiency.

The infinitely adjustable steering column and armrest allow for adjustment to suit all operator sizes. The individual adjustment of the controls is very easy to carry out thanks to the single-point adjustment via two adjustable axes.

The truck chassis is closed on the right side of the operator. This guarantees maximum rigidity and stability for the overall design. It also forms the basis for a number of storage options: From two sizes of cup holder via a clipboard to different sizes of compartments for e.g. papers and a smartphone. There is therefore room for everything that operators need to work efficiently throughout their shifts.

EFG 425k/425/430k/430/S30

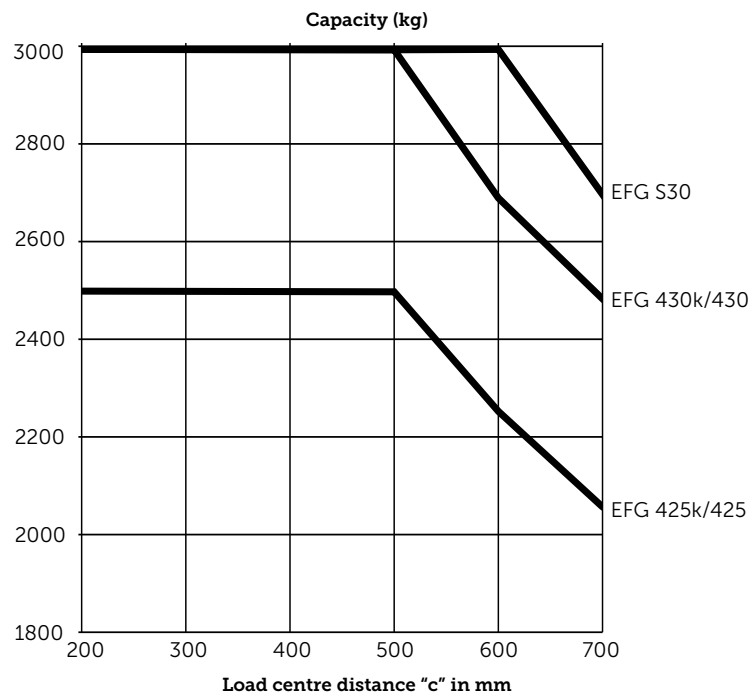
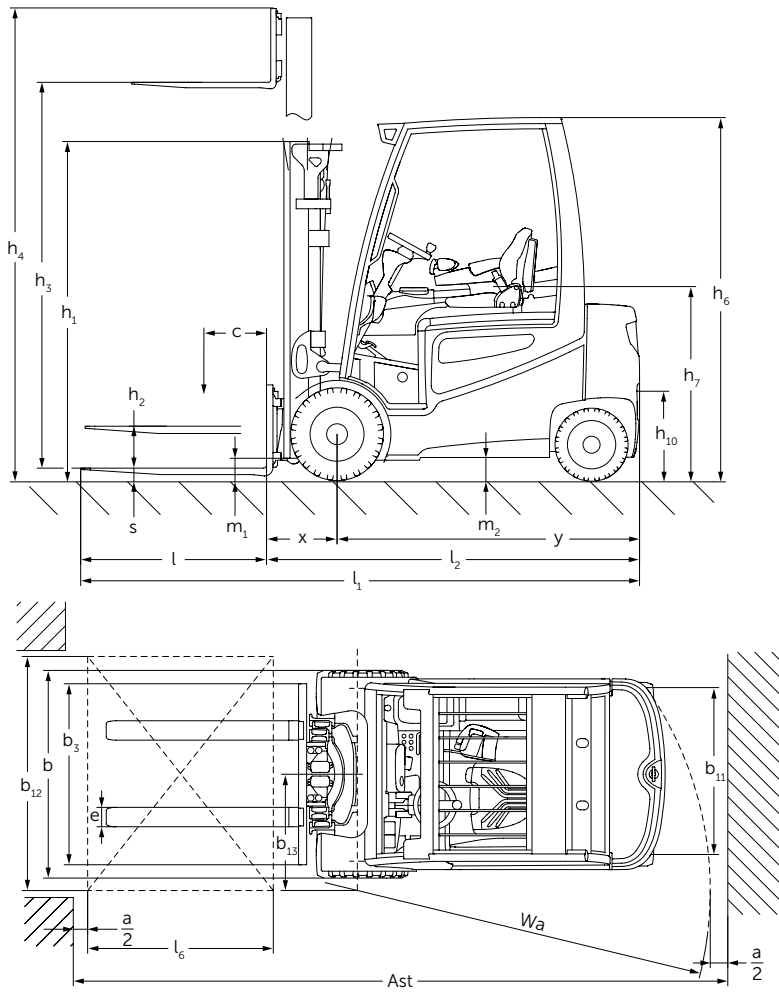

EFG 425k/425/430k/430/S30

Standard mast types EFG 425k/425/430k/430/S30								
	Lift h_3	Lowered mast height h_1		Free lift h_2		Extended mast height h_4		Mast tilt forward / back α/β (°)
	(mm)	(mm)		(mm)		(mm)		
		EFG 425k / 425	EFG 430k / 430 / S30	EFG 425k / 425	EFG 430k / 430 / S30	EFG 425k / 425	EFG 430k / 430 / S30	
Duplex ZT	2900	2125	2122	150	150	3502	3659	6/8
	3100	2225	2222	150	150	3702	3859	6/8
	3300	2325	2322	150	150	3902	4059	6/8
	3500	2425	2422	150	150	4102	4259	6/8
	3700	2525	2522	150	150	4302	4459	6/8
	4000	2675	2672	150	150	4602	4759	6/8
	4300	2875	2872	150	150	4902	5059	6/8
	4500	2975	2972	150	150	5102	5259	6/8
Duplex ZZ	3100	2190	2187	1609	1448	3680	3839	6/8
	3300	2290	2287	1709	1548	3880	4039	6/8
	3500	2390	2387	1809	1648	4080	4239	6/8
	3700	2490	2487	1909	1748	4280	4439	6/8
	4000	2640	2637	2059	1898	4580	4739	6/8
Triplex DZ	4400	2090	2087	1509	1348	4980	5139	6/8
	4700	2190	2187	1609	1448	5280	5439	6/5.5
	5000	2290	2287	1709	1548	5580	5739	6/5.5
	5500	2490	2487	1909	1748	6080	6239	6/5.5
	6000	2690	2687	2109	1948	6580	6739	6/5.5
	6500	2890	2887	2309	2148	7080	7239	6/3
	7000	3090	3087	2509	2348	7580	7739	6/3
	7500	3290	3287	2709	2548	8080	8239	6/3

Technical data in line with VDI 2198

		Jungheinrich				
		EFG 425k	EFG 425	EFG 430k		
Identification	1.1	Manufacturer (short form)		Jungheinrich		
	1.2	Model		EFG 425k		
	1.3	Drive		Electrics		
	1.4	Manual, pedestrian, stand-on, seated, order picker operation		seat		
	1.5	Load capacity/rated load	Q t	2.5	2.5	3
	1.6	Load centre distance	c mm	500		
Weights	1.8	Load distance	x mm	425	425 ¹⁾	447
	1.9	Wheelbase	y mm	1575	1720	1575
	2.1.1	Net weight incl. battery (see row 6.5)	kg	4770	4680	5260
	2.2	Axle load, w. load, front / rear	kg	6440 / 830	6590 / 590	7360 / 910
	2.3	Axle load, w.o. load, front / rear	kg	2450 / 2320	2720 / 1960	2530 / 2730
	Wheels / chassis	3.1	Tyres		SE	
3.2		Tyre size, at front	mm	225 / 75-10	225 / 75-10	250 / 60-12
3.3		Tyre size, at rear	mm	180 / 70-8	180 / 70-8	200 / 50-10
3.5		Wheels, number front/rear (x = driven wheels)		2X / 2		
3.6		Track width, front	b ₁₀ mm	990	990	950
3.7		Track width, rear	b ₁₁ mm	940		
Basic dimensions		4.1	Tilt of mast/fork carriage forward/backward		α/β °	
	4.2	Mast height (lowered)	h ₁ mm	2225	2225	2222
	4.3	Free lift	h ₂ mm	150		
	4.4	Lift	h ₃ mm	3100		
	4.5	Extended mast height	h ₄ mm	3702	3702	3859
	4.7	Height of overhead guard	h ₆ mm	2240		
	4.8	Seat height/stand height	h ₇ mm	1190		
	4.12	Coupling height	h ₁₀ mm	385		
	4.12.1	2nd coupling height	mm	540		
	4.19.4	Total length including fork length	l ₁ mm	3446	3591	3467
	4.20	Length incl. back of forks	l ₂ mm	2296	2441	2317
	4.21	Total width	b ₁ /b ₂ mm	1198		
	4.22	Fork dimensions	s/e/l mm	40 / 120 / 1150	40 / 120 / 1150	45 / 125 / 1150
	4.23	Fork carriage ISO 2328, class/type A, B		2A	2A	3A
	4.24	Fork carriage width	b ₃ mm	1120		
	4.31	Floor clearance with load under mast	m ₁ mm	117		
4.32	Floor clearance centre wheelbase	m ₂ mm	135			
4.33	Aisle width for pallets 1000 x 1200 sideways	Ast mm	3626	3776	3647	
4.34	Aisle width for pallets 800 x 1200 lengthways	Ast mm	3826	3976	3847	
4.35	Turning radius	W _a mm	2000	2150	2000	
4.36	Smallest pivot point distance	b ₁₃ mm	600			
Performance data	5.1	Travel speed laden/unladen - Efficiency	km/h	16 / 17		
		Travel speed laden/unladen - Drive&Lift Plus	km/h	19 / 20		
	5.2	Lift speed, laden/unladen - Efficiency	m/s	0.43 / 0.55	0.43 / 0.55	0.4 / 0.55
		Lift speed, laden/unladen - Drive&Lift Plus	m/s	0.48 / 0.6	0.48 / 0.6	0.43 / 0.6
	5.3	Lowering speed laden/unladen - Efficiency	m/s	0.58 / 0.58		
		Lowering speed laden/unladen - Drive&Lift Plus	m/s	0.58 / 0.58		
	5.5	Drawbar pull laden/unladen - Efficiency	N	3600 / 4000	3500 / 3900	4500 / 5000
		Drawbar pull laden/unladen - Drive&Lift Plus	N	5100 / 5600	4900 / 5500	5000 / 5800
	5.6	Max. drawbar pull laden/unladen - Efficiency	N	12500 / 13000	12500 / 13000	14000 / 14500
		Max. drawbar pull laden/unladen - Drive&Lift Plus	N	16000 / 16300	16000 / 16300	15700 / 16000
5.7	Gradeability laden/unladen - Efficiency	%	8.5 / 14	7.5 / 13	7 / 12	
	Gradeability laden/unladen - Drive&Lift Plus	%	10 / 16	10 / 16	9 / 15	
5.8	Max. gradeability laden/unladen - Efficiency	%	17 / 25	17 / 25	15 / 23	
	Max. gradeability laden/unladen - Drive&Lift Plus	%	19 / 27	19 / 27	17 / 25	
5.9.1	Acceleration time laden/unladen (over 10 m) - Efficiency	S	5 / 4.5			
	Acceleration time laden/unladen (over 10 m) - Drive&Lift Plus	S	4.5 / 4			
5.10	Service brake		mechanical			
Electrics	6.1	Drive motor, rating S2 60 min. - Efficiency/Drive&Lift Plus	kW	12 / 15		
	6.2	Lift motor, rating at S3 15% - Efficiency/Drive & Lift Plus	kW	18.5 / 22		
	6.3	Battery according to DIN 43531/35/36 AB,C, no		A 43536		
	6.4	Battery voltage/nominal capacity KS	V/Ah	560 - 620 80	700 - 775 80	560 - 620 80
	6.5	Battery weight	kg	1540	1863	1540
		Battery dimensions L/W/H	mm	1028 / 711 / 784	1028 / 855 / 784	1028 / 711 / 784
	6.6	Energy consumption according to VDI cycle Efficiency/Drive&Lift Plus	kWh/h	6.4 / 6.4 ²⁾	6.4 / 6.4 ²⁾	8 / 8 ²⁾
	6.7	Efficiency/Drive&Lift Plus throughput	t/h	186 / 196	186 / 196	211 / 225
6.8	Energy consumption at max. Efficiency/Drive&Lift Plus throughput	kWh/h	7 / 7.9	7 / 7.9	7.2 / 8.6	
Misc.	8.1	Type of drive control		Impuls/AC		
	8.2	Working pressure for attachments	bar	200		
	8.3	Oil flow for attachments	l/min	25		
	8.4	Sound pressure level at operator's ear according to EN 12053	dB (A)	70		
	8.5	Trailer coupling, model/type DIN		DIN 15170-H		

¹⁾ + 10 mm for DZ mast

²⁾ 60 VDI work cycles/h

In accordance with VDI Guideline 2198 this specification sheet provides details of the standard truck only. Non-standard tyres, different masts, optional equipment, etc. may result in different values.

Technical data in line with VDI 2198

				Jungheinrich		
				EFG 430	EFG 530	
Identification	1.1	Manufacturer (short form)		Jungheinrich		
	1.2	Model				
	1.3	Drive		Electrics		
	1.4	Manual, pedestrian, stand-on, seated, order picker operation		seat		
	1.5	Load capacity/rated load	Q	t	3	
	1.6	Load centre distance	c	mm	500	600
	1.8	Load distance	x	mm	447	452
	1.9	Wheelbase	y	mm	1720	
	Weights	2.1.1	Net weight incl. battery (see row 6.5)		5080	5330
2.2		Axle load, w. load, front / rear		7450 / 630	7620 / 710	
2.3		Axle load, w.o. load, front / rear		2770 / 2310	2780 / 2550	
Wheels / chassis	3.1	Tyres		SE		
	3.2	Tyre size, at front		250 / 60-12	315 / 45-12	
	3.3	Tyre size, at rear		180 / 70-8	200 / 50-10	
	3.5	Wheels, number front/rear (x = driven wheels)		2X / 2		
	3.6	Track width, front	b ₁₀	mm	950	1000
	3.7	Track width, rear	b ₁₁	mm	940	
	Basic dimensions	4.1	Tilt of mast/fork carriage forward/backward		α/β °	
4.2		Mast height (lowered)		h ₁ mm		
4.3		Free lift		h ₂ mm		
4.4		Lift		h ₃ mm		
4.5		Extended mast height		h ₄ mm		
4.7		Height of overhead guard		h ₆ mm		
4.8		Seat height/stand height		h ₇ mm		
4.12		Coupling height		h ₁₀ mm		
4.12.1		2nd coupling height		mm		
4.19.4		Total length including fork length		l ₁	mm	3612
4.20		Length incl. back of forks		l ₂	mm	2462
4.21		Total width		b ₁ /b ₂	mm	1198
4.22		Fork dimensions		s/e/l	mm	45 / 125 / 1150
4.23		Fork carriage ISO 2328, class/type A, B		3A		
4.24		Fork carriage width		b ₃	mm	1120
4.31		Floor clearance with load under mast		m ₁	mm	117
4.32		Floor clearance centre wheelbase		m ₂	mm	135
4.33	Aisle width for pallets 1000 x 1200 sideways		Ast	mm	3797	
4.34	Aisle width for pallets 800 x 1200 lengthways		Ast	mm	3997	
4.35	Turning radius		W _a	mm	2150	
4.36	Smallest pivot point distance		b ₁₃	mm	600	
Performance data	5.1	Travel speed laden/unladen - Efficiency		km/h		
		Travel speed laden/unladen - Drive&Lift Plus		km/h		
	5.2	Lift speed, laden/unladen - Efficiency		m/s		
		Lift speed, laden/unladen - Drive&Lift Plus		m/s		
	5.3	Lowering speed laden/unladen - Efficiency		m/s		
		Lowering speed laden/unladen - Drive&Lift Plus		m/s		
	5.5	Drawbar pull laden/unladen - Efficiency		N		
		Drawbar pull laden/unladen - Drive&Lift Plus		N		
	5.6	Max. drawbar pull laden/unladen - Efficiency		N		
		Max. drawbar pull laden/unladen - Drive&Lift Plus		N		
	5.7	Gradeability laden/unladen - Efficiency		7 / 13	7 / 12	
		Gradeability laden/unladen - Drive&Lift Plus		9 / 15	8 / 14	
	5.8	Max. gradeability laden/unladen - Efficiency		%		
	Max. gradeability laden/unladen - Drive&Lift Plus		18 / 26	17 / 25		
5.9.1	Acceleration time laden/unladen (over 10 m) - Efficiency		s			
	Acceleration time laden/unladen (over 10 m) - Drive&Lift Plus		s			
5.10	Service brake		mechanical			
Electrics	6.1	Drive motor, rating S2 60 min. - Efficiency/Drive&Lift Plus		kW		
	6.2	Lift motor, rating at S3 15% - Efficiency/Drive & Lift Plus		kW		
	6.3	Battery according to DIN 43531/35/36 AB,C, no		A 43536		
	6.4	Battery voltage/nominal capacity K5		V/Ah		
	6.5	Battery weight		kg		
		Battery dimensions L/W/H		mm		
	6.6	Energy consumption according to VDI cycle Efficiency/Drive&Lift Plus		8 / 8 ¹⁾	8.1 / 8.1 ¹⁾	
	6.7	Efficiency/Drive&Lift Plus throughput		211 / 225	207 / 220	
6.8	Energy consumption at max. Efficiency/Drive&Lift Plus throughput		7.2 / 8.6	8.1 / 9.5		
Misc.	8.1	Type of drive control		Impuls/AC		
	8.2	Working pressure for attachments		bar		
	8.3	Oil flow for attachments		l/min		
	8.4	Sound pressure level at operator's ear according to EN 12053		dB (A)		
	8.5	Trailer coupling, model/type DIN		DIN 15170-H		

¹⁾ 60 VDI work cycles/h

EFG 425k/425/430k/430/S30



Benefit from the advantages



Sideways battery removal



DUO-PILOT



Ergonomic workstation



Storage facilities

Pure Energy

Our Pure Energy technology concept enables you to achieve the best possible energy efficiency coupled with maximum throughput:

- Most advanced 3-phase AC technology.
- Compact controller.
- Compact hydraulic unit.
- Demands-oriented control of the hydraulics/motors.

Options packages

The right truck for every customer application. The Efficiency and Drive&Lift Plus packages make it possible:

Efficiency package:

- Jungheinrich Curve Control.

Drive&Lift Plus package:

- Performance package with greater travel/lift speeds.

Parameter steering

Electric steering with dynamic response dependent on the travel program selected.

- Minimises unwanted steering changes.
- Slim steering column creates more legroom.
- Further improved energy efficiency.
- Further optimised throughput.

Sideways battery exchange

- Universal battery exchange system for all 48 V and 80 V trucks.
- Simple, rapid and reliable exchange system.

Individually adjustable operating concept

- A choice of five parameterised travel programmes.
- Stepless single-point adjustment of the armrest and steering column in two axes.
- A choice of three different operating controls.
- Adjustable lever and controls.
- Single or double pedal operation.

Operator-oriented workstation

The ergonomics of the operator's workstation guarantee relaxed, fatigue-free work:

- Low, highlighted entry step with level foot-well.
- Slim steering column for maximum knee and legroom.
- High-resolution, contrast-rich full-colour TFT display with self-explanatory symbols.
- Unobstructed view thanks to special overhead guard design, optimised chain and hose configuration.
- Operator-oriented storage concept for intuitive working
- Large, adjustable armrest with different upholstery fabrics and spacious storage compartment

- USB port for external power supply
- Low vibrations as the cab floats on special mountings

Safety

High drive dynamics and performance levels also require a high level of safety:

- Reduction in speed when cornering thanks to Jungheinrich Curve Control.
- No uncontrolled roll-back on ramps or inclines due to automatic parking brake (optional).
- Excellent stability due to extremely low centre of gravity and high pivot steer axle.

A range of optional operator assistance systems (optional) provides additional safety for the operator, truck and load:

- Access Control: The access control system releases the truck only after a sequence of safety checks:

1. Valid access code.
2. Closed seat switch.
3. Seatbelt is secured.

- Drive Control: The speed control which automatically reduces the speed of travel when cornering and from a defined lift height.

- Lift Control: The lift speed control which, in addition to reducing travel speed, also automatically reduces the tilt speed of the mast from a defined lift height. The tilt angle is shown on a separate display.

Jungheinrich UK Ltd.

Head Office:
Sherbourne House
Sherbourne Drive
Tilbrook
Milton Keynes MK7 8HX
Telephone 01908 363100
Fax 01908 363180

info@jungheinrich.co.uk
www.jungheinrich.co.uk

The German production facilities in Norderstedt and Moosburg are certified. **ISO 9001**
ISO 14001

Jungheinrich fork lift trucks meet European safety requirements.



JUNGHEINRICH
Machines. Ideas. Solutions.